

# FIREMAGIC AURORA

## ISLAND OUTDOOR GAS GRILLS

A430i, A530i, A540i, A660i & A790i

### INSTALLATION INSTRUCTIONS AND OWNER'S MANUAL

**INSTALLER:** Leave these instructions with consumer.  
**CONSUMER:** Retain for future reference.



A790i shown

**IMPORTANT:** READ THESE INSTRUCTIONS CAREFULLY BEFORE STARTING INSTALLATION OR USE.

## WARNINGS AND SAFETY CODES

### **⚠ DANGER:**

#### **IF YOU SMELL GAS:**

1. Shut off the gas to the appliance.
2. Extinguish any open flame.
3. Open lid.
4. If odor continues, keep away from the appliance and **immediately** call your gas supplier or the fire department.

### **⚠ WARNING:**

1. Do not store or use gasoline or other flammable vapors and liquids in the vicinity of this or any other appliance.
2. An LP cylinder not connected for use shall not be stored in the vicinity of this or any other appliance.

**CODE AND SUPPLY REQUIREMENTS:** This grill must be installed in accordance with local codes and ordinances, or, in the absence of local codes, with the latest *National Fuel Gas Code (ANSI Z223.1/NFPA 54)*, or *Natural Gas and Propane Storage and Handling Installation Code (CSA-B149.1)*.

This appliance and its dedicated manual shutoff valve must be disconnected from the gas-supply piping system when testing the system at pressures in excess of ½ psig (3.5 kPa).

This appliance must be isolated from the gas-supply piping system by closing its dedicated manual shutoff valve during any pressure testing of the gas-supply system at pressures up to and including ½ psig (3.5 kPa).

### **⚠ WARNING:**

Improper installation, adjustment, alteration, service, or maintenance can cause injury or property damage. For proper installation, refer to the installation instructions. For assistance or additional information, consult a qualified professional installer, service agency, or the gas supplier.

**Certified to ANSI: Z21.58-2007**

All electrical outlets in the vicinity of the grill must be properly grounded in accordance with local codes, or, in the absence of local codes, with the *National Electrical Code, ANSI/NFPA 70*, or the *Canadian Electrical Code, CSA C22.1*, whichever is applicable.

Keep all electrical-supply cords and fuel-supply hoses away from any heated surface.



Robert H. Peterson Co. • 14724 East Proctor Avenue • City of Industry, CA 91746

# - INSTALLATION INSTRUCTIONS ET MANUEL DU PROPRIÉTAIRE -

## GRIL EXTÉRIEUR DE GAZ DU SLIDE-IN

**IMPORTANT:** LISEZ CES INSTRUCTIONS SOIGNEUSEMENT AVANT DE COMMENCER L'INSTALLATION OU L'UTILISATION

### SÛRETÉ ET CODES D'AVERTISSEMENT

#### **▲ DANGER:**

##### **SI VOUS SENTEZ LE GAZ :**

1. Coupez le gaz à l'appareil.
2. Éteignez-vous n'importe quelle flamme nue.
3. Ouvrez le couvercle.
4. Si l'odeur continue, gardez loin de l'appareil et appelez immédiatement votre département de fournisseur ou de feu de gaz.

#### **CONDITIONS DE CODE ET D'APPROVISIONNEMENT:**

Ce gril doit être installé selon des codes et des ordonnances locaux, ou, en l'absence des codes locaux, avec l'un ou l'autre le plus défunt *Code national de gaz de carburant* (norme ANSI Z223.1/NFPA 54), et *Stockage de gaz naturel et de propane et manipulation du code d'installation* (CSA-B149.1).

Cet appareil et ses différents robinets d'isolement doivent être démontés du gaz-fournissent le système sifflant en examinant le système aux pressions au-dessus du ½ psig (kPa 3.5).

Cet appareil doit être isolé dans gaz-fournissent le système sifflant par fermeture que ses différents robinets d'isolement manuels pendant tous les essais sous pression du gaz-fournissent le système aux pressions jusques et y compris le ½ psig (kPa 3.5).

- Ce gril est pour utilisation à l'extérieur seulement. Si l'appareil est entreposé à l'intérieur, enlever les bouteilles et les laisser à l'extérieur.
- Ne pas ranger le gril immédiatement après l'avoir utilisé. le laisser refroidir avant de le déplacer ou de la ranger. Le non respect de cette mesure de sécurité pourrait entraîner un incendie causant des dommages à la propriété, des blessures ou la mort.
- Ne pas utiliser cet appareil sous une surface combustible.
- Ne pas utiliser cet appareil sous un auvent. Le non respect de cette mesure de sécurité pourrait entraîner un incendie ou des blessures.
- Dégagement minimal entre les parois latérales et l'arrière de l'appareil et la construction combustible (45.7 cm à partir des parois latérales et 45.7cm à partir de l'arrière).
- Le régulateur de pression de gaz prévu avec cet appareil de cuisson à gaz pour l'extérieur doit être utilisé. Ce régulateur est réglé pour une pression de sortie de 5 pouces de colonne de l'eau pour le gaz naturel, et 10 pouces pour le propane.
- LE RÉGULATEUR INCLUS D'APPAREILS EST ÉVALUÉ POUR LE MAXIMUM DE 1/2 (LIVRES PAR POUCE CARRÉ). SI VOTRE OFFRE DE GAZ EST 1/2 PLUS GRAND QUE (LIVRES PAR POUCE CARRÉ), UN

#### **▲ AVERTISSEMENT:**

1. Ne stockez pas ou n'employez pas l'essence ou d'autres vapeurs et liquides inflammables à proximité de ceci ou d'aucun autre appareil.
2. Un cylindre de propane non relié pour l'usage ne sera pas stocké à proximité de ceci ou d'aucun autre appareil.

#### **▲ AVERTISSEMENT:**

L'installation inexacte, l'ajustement, le changement, le service, ou l'entretien peuvent causer des dommages ou des dégâts matériels. Référez-vous à ce manuel. Pour l'aide ou l'information additionnelle, consultez un installateur professionnel qualifié, l'agence de service, ou le fournisseur de gaz.

Toutes les sorties électriques à proximité du gril doivent être correctement fondues selon des codes locaux, ou en l'absence de local code, avec le code électrique national, ANSI/NFPA 70, ou le code électrique canadien, CSA C22.1, celui qui est applicable.

Maintenez tout électrique-fournissent des cordes et carburant-fournissent des tuyaux partis de n'importe quelle surface de chauffage.

**RÉGULATEUR ADDITIONNEL DOIT ÊTRE INSTALLÉ AVANT LE GRIL. VOIR LA SECTION DE CONDITIONS D'OFFRE DE GAZ POUR LA PRESSON APPROPRIÉE D'OFFRE DE GAZ.**

- Ne couvrez jamais la surface entière de cuisine ou de gril de gauffreuses ou de casseroles. La surchauffe se produira et les brûleurs ne seront pas très performants quand la chaleur de combustion est emprisonnée au-dessous de la surface à cuire.
- Ne pulvérisez jamais l'eau sur une unité chaude de gaz, comme ceci peut endommager des composants de porcelaine ou de fer de fonte.
- Une fuite de GPL peut causer un incendie ou une explosion si enflammée entraînant des blessures corporelles graves ou la mort.
- Communiquez avec le fournisseur de GPL pour les réparations ou pour disposer de qules bouteille ou du GPL non utilisé.

**Certifié à la norme ANSI : Z21.58-2007**

**INSTALLATEUR :** Laissez ces instructions avec le consommateur.  
**CONSOMMATEUR :** Maintenez pour la future référence.

## CONTENTS

<u>Page</u>	<u>Section</u>
4	PARTS LIST
5	GRILL MAINTENANCE AND SAFETY INFORMATION
5	MODEL SPECIFICATIONS
6	INSTALLATION REQUIREMENTS
6	ENSURING PROPER COMBUSTION AIR AND COOLING AIRFLOW
6	EXHAUST REMOVAL
6	GAS-SUPPLY PLUMBING REQUIREMENTS
7	INSTALLING THE SLIDE-IN UNIT
7	COUNTER PREPARATION
7	CONNECTING THE GAS SUPPLY
9	SAFE USE & MAINTENANCE OF PROPANE-GAS CYLINDERS
11	LIGHTING (IGNITION) INSTRUCTIONS
13	AURORA DIGITAL THERMOMETER
14	INFRARED BURNER OPERATION
15	ROTISSERIE INSTRUCTIONS
16	ACCESSORIES
16	THE COOKING GRID LIFTER
16	THE DRIP PAN
16	THE FLAVOR GRID(S)
16	THE WARMING RACK
17	FIRE MAGIC® DRIP TRAY
18	CARE & CLEANING
18	OPTIONAL COVER
19	TROUBLESHOOTING
20	CONVERTING THE GAS TYPE
20	REGULATOR CONVERSION
20	GAS ORIFICE CONVERSION
22	BURNER AIR SHUTTER ADJUSTMENT
24	WARRANTY



# MODEL SPECIFICATIONS

## Fire-Magic® Model Specifications Table

Table 1	A430i	A530i	A540i	A660i	A790i
Countertop to unit bottom (cut-out)*	12"	12"	12"	12"	12"
Side to side (noncombustible cut-out)*	25-1/2"	25-1/2"	32"	32"	37-3/4"
Front to back (noncombustible cut-out)*	19-1/2"	23-1/2"	19-1/2"	23-1/2"	23-1/2"
Control Panel width	26-1/2"	26-1/2"	32-1/2"	32-1/2"	38-1/4"
Main burner BTU N/P orifice drill size	25,000 #42/#54	30,000 #40/#53	25,000 #42/#54	20,000 #44/#55	30,000 #38/#53
Backburner BTU N/P orifice drill size	16,000 #58/#50	16,000 #58/#50	20,000 #47/#55	20,000 #47/#55	23,000 #42/#55
Sideburner BTU N/P orifice drill size	10,000 #53/#63	10,000 #53/#63	10,000 #53/#63	10,000 #53/#63	10,000 #53/#63
Infrared searing burner BTU N/P orifice drill size	18,500 #46/#56	24,000 #45/#55	24,000 #45/#55	18,500 #46/#56	24,000 #45/#55

**\*Note:** If using an insulating liner, consult liner instructions for counter cut-out dimensions.

### TOP VIEW

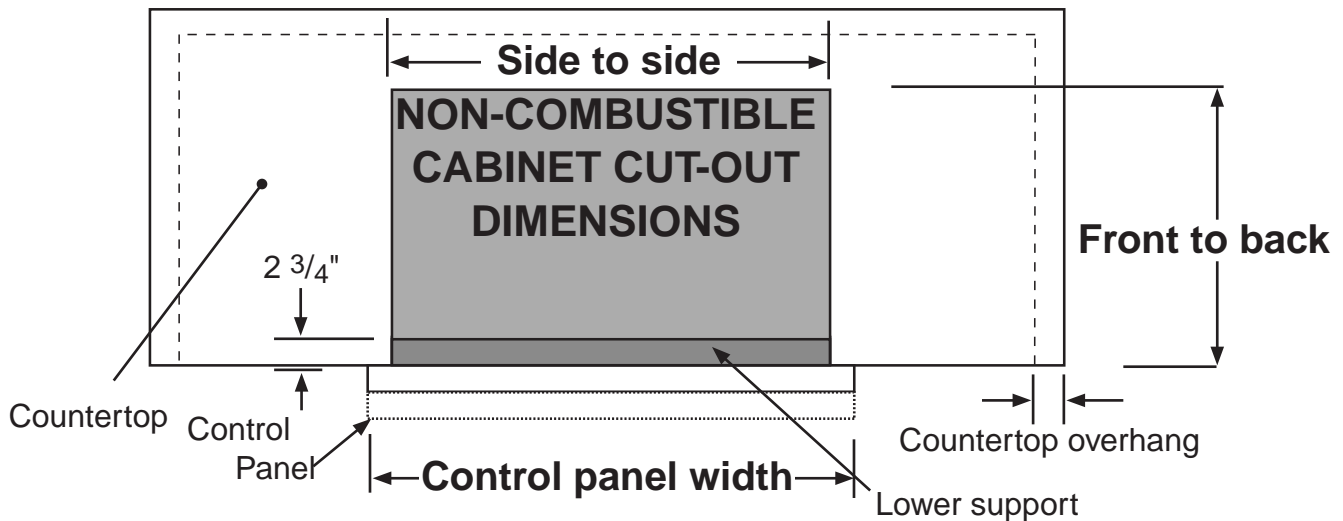

### GRILL MAINTENANCE AND SAFETY INFORMATION

**Each time you light this grill:**

1. The outdoor grill and surrounding area **MUST** remain clear of flammable substances such as gasoline, yard debris, wood, etc.
2. The airflow through the vent space located below the control panel must remain unobstructed.
3. When using propane gas:
  - a. **The required ventilation openings in the enclosure must be clear of debris.**
  - b. **The propane cylinder, regulator, and rubber hose must be in a location not subject to temperature above 125° F (51° C).**
4. The flames on each burner burn evenly along the entire burner with a steady flame (mostly blue with yellow tipping). If burner flames are not normal, check the orifice and burner for insects or insect nests. Adjust the air shutter as needed (see AIR SHUTTER ADJUSTMENT)
5. The in-line gas valve or gas cylinder valve must always be shut OFF when the grill is not in use.
6. The drip collector holes must be clear and unobstructed. Excessive grease deposits can result in a grease fire.
7. The backburner or IR burner cover must be removed before using the burner.

**WARNING: NEVER cover the entire cooking or grill surface with griddles or pans. Overheating will occur, and burners will not perform properly when combustion heat is trapped below the cooking surface.**

**CAUTION: NEVER spray water on a hot gas unit.**

## INSTALLATION REQUIREMENTS

This grill is designed for outdoor use only. **DO NOT** use this grill under unprotected flammable surfaces. **DO NOT** use this grill inside a building, garage, enclosed area, or an unprotected covered area (see EXHAUST REMOVAL below). **DO NOT** use this grill in or on a recreational vehicle or boat.

**IMPORTANT:** When installing this grill in a combustible surround, an R. H. Peterson insulating liner must be used. The unit must have a minimum of 18" (45.7 cm) of clearance from combustible construction to the right, left, and back. See Fire Magic® installation guide.

The control panel **MUST** remain removable for servicing and air shutter adjustment (see PARTS LIST).

### ENSURING PROPER COMBUSTION AIR AND COOLING AIRFLOW

Proper airflow (Fig. 6-1) **MUST** be maintained for the grill to perform as it was designed. If airflow is blocked, overheating and poor combustion will result. Do not block the 1" (2.5 cm) front air inlet along the bottom of the control panel or more than 75% of the cooking grid surface with pans or griddles.

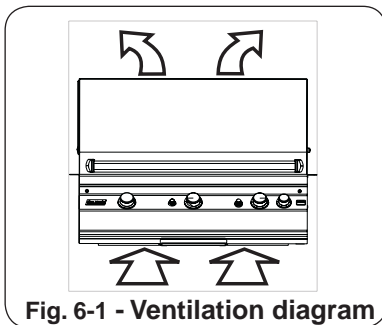

Fig. 6-1 - Ventilation diagram

**Note:** The 1" (2.5 cm) front air space also allows access to the drip tray.

### EXHAUST REMOVAL

If installed or used under a patio roof, the cooking grid area must be fully covered by an exhaust hood with a chimney. An exhaust fan with a rating of 1,000 CFM (cubic feet per minute) (472 liters per second) or more may be necessary to effectively remove smoke and other cooking by-products from the area under the hood. This grill must not be used under overhead combustible construction. **THIS UNIT MUST NOT BE LOCATED IN A FULLY ENCLOSED AREA OF ANY KIND.**

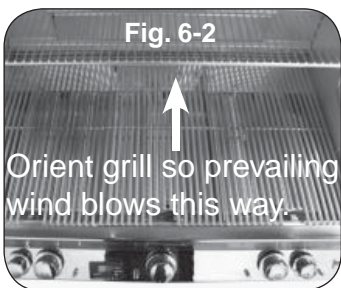

Fig. 6-2

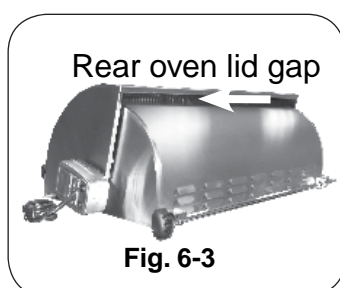

Fig. 6-3

### GAS-SUPPLY PLUMBING REQUIREMENTS

For natural gas or a household propane system, rigid 1/2" (1.3 cm) or 3/4" (1.9 cm) black steel pipe or local code-approved pipe is required to conduct the gas supply to the unit. Connect this pipe to the required C.S.A.-approved stainless-steel flex connector (attached). An NPT adapter has been provided for 1/2" pipe. **DO NOT use a rubber hose within the grill enclosure.** Apply only joint compounds that are resistant to all gasses to all male pipe fittings except flare fittings. Make sure to tighten every joint securely.

**Note:** If 1/2" (1.3 cm) pipe is used with **natural gas**, it should be no longer than 20' (6.1 meters).

**Important:** An external valve (with a removable key) in the gas line is necessary for safety when the grill is not in use. It also provides for convenient maintenance.

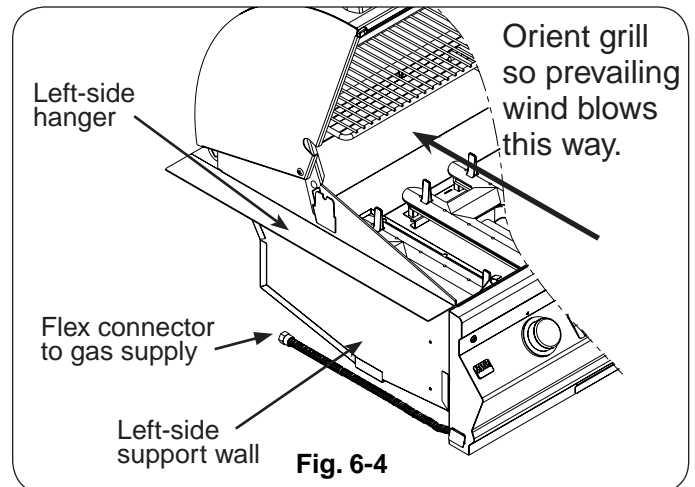

Fig. 6-4

**CAUTION:** DO NOT operate the grill with air blowing into or across the rear oven lid gap (Fig. 6-3). This can cause poor performance and/or dangerous overheating of the control panel. Orient the grill so that any prevailing wind blows against the front of the grill (Fig. 6-2).

# INSTALLING THE SLIDE-IN UNIT

## COUNTER PREPARATION

Consult Table 1 for non-combustible enclosure cut-out dimensions. A Robert H. Peterson insulating liner must be used if the counter or any supporting construction is combustible. Consult the instructions that come with the liner for dimensions and additional installation information before beginning the installation.

This outdoor built-in grill must supported by the stainless-steel hanger extending from the upper portion of the grill. The hanger rests on the left, right, and back of the countertop and on the two front structural supports with attached levelers located below the control panel on the left and right sides (see Fig. 7-3).

The control panel is designed to sit flush against the cabinet face (see Fig. 7-2). If the countertop extends beyond the cabinet face, creating a countertop overhang (see Fig. 7-1), it must be cut flush with the cabinet face where the for the width of the control panel or a gap will be created exposing the forward portions of the left and right side fire walls.

**Note:** It is not necessary to remove the control panel or knobs to install this unit.

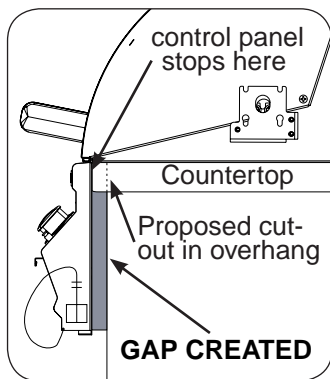

Fig. 7-1

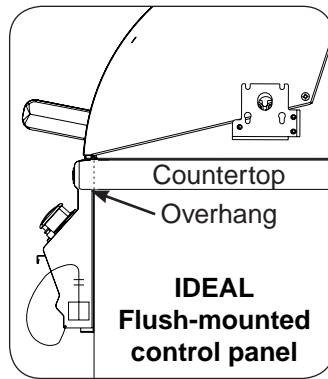

Fig. 7-2

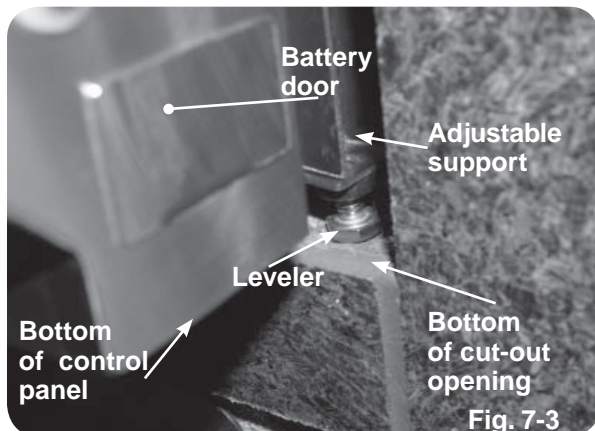

Fig. 7-3

## CONNECTING THE GAS SUPPLY

**CAUTION:** Use only C.S.A. listed stainless-steel flex connectors within the enclosure.

### WARNING

**A rubber or plastic connector will rupture or leak, resulting in an explosion or serious injury if used inside the appliance enclosure.**

- Run the attached flex connector routed under the left side of the grill out of the enclosure and to the gas stub.
- Turn OFF the gas supply at the source.** Then connect the  $\frac{1}{2}$ " pipe adapter fitting supplied with the stainless-steel flex connector to the gas-supply stub. Use pipe joint compound that is resistant to all gasses on the male pipe fitting and tighten securely. **DO NOT use pipe joint compound to connect flare fittings.**
- Turn all burner control knobs to the **OFF** position. Turn the gas supply on. Then carefully check *all* gas connections for leaks with a brush and half-soap/half-water solution before lighting. **NEVER USE A MATCH OR OPEN FLAME TO TEST FOR LEAKS.**
- Close the dedicated gas-supply shut-off valve, then slide the grill into place. Do not to pinch, kink, or damage the gas connector line.
- Rotate the levelers to the left to raise and to the right to lower the respective side of the appliance grill it is level. Use a  $\frac{7}{16}$ " open-end wrench as needed.

**Important:** Do not extend the levelers so far that any part of the hanger is raised off the counter top.

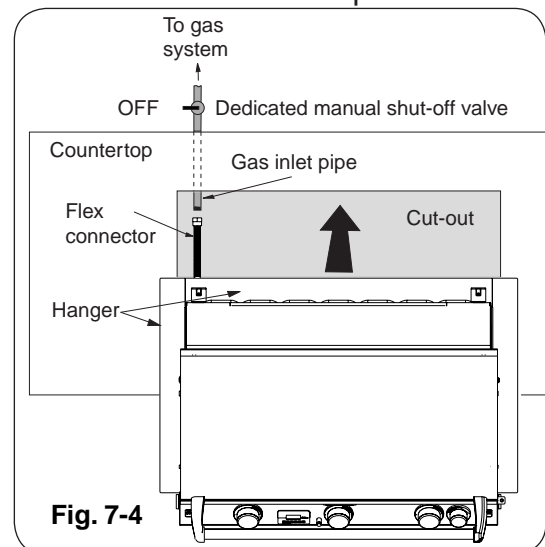

# UTILISATION SÛRE ET ENTRETIEN DES CYLINDRES DE GAZ

## IMPORTANT POUR VOTRE SÛRETÉ

### LISEZ ET SUIVEZ TOUS LES AVERTISSEMENTS ÉQUIPÉS DE VOTRE CYLINDRE DE GAZ DE PROPANE.

En actionnant cet appareil avec un cylindre de gaz de propane ON DOIT observer ces instructions et avertissements.

### LE MANQUE DE FAIRE AINSI PEUT AVOIR COMME CONSÉQUENCE UNE INCENDIE OU UNE EXPLOSION SÉRIEUSE.

#### CYLINDRE ET CONDITIONS ET

#### CARACTÉRISTIQUES DE CONNECTEUR

- Des cylindres et les valves de gaz de propane doivent être maintenus en bon état et doivent être remplacés s'il y a des dommages évidents au cylindre ou à la valve.
- Ce gril, une fois utilisé avec un cylindre, devrait être relié à un gallon de la norme 5 (20lb.) cylindre de gaz de propane équipé d'un OPD (remplissez au-dessus du niveau le dispositif d'empêchement). L'OPD a été exigé sur tous les cylindres vendus depuis octobre 1.1998 pour empêcher le remplissage excessif.
- Les dimensions de cylindre devraient être approximativement 12" (30.5cm) de diamètre et 18" (45.7cm) hauts. Des cylindres doivent être construits et marqués selon les caractéristiques pour des cylindres de gaz de propane du département des ETATS-UNIS du transport (D.O.T.) ou le niveau national du Canada, du CAN/CSA-B339, des cylindres, des sphères et des tubes pour le transport des marchandises dangereuses.
- Le cylindre doit inclure un collier pour protéger la valve de cylindre et le circuit d'alimentation de cylindre doit être assuré le retrait de vapeur.
- Le régulateur de pression et l'ensemble de tuyau (fig. 8-1) fourni avec cet appareil à cuire extérieur de gaz doivent être utilisés. Les régulateurs d'original et de pression de remplacement et les ensembles de tuyau doivent être ceux indiqués par le fabricant pour le raccordement avec un dispositif se reliant de cylindre identifié comme type I par la norme ANSI Z 21.58-2007/CGA 1.6-2007 avec la norme ANSI Z 21.58a -1998 d'addenda et CGA 1.6a - M98.
- La valve de cylindre de gaz de propane doit être équipée d'un dispositif d'accouplement de raccordement de cylindre, décrit comme type I dans la norme définie dans le e. de paragraphe ci-dessus. Ce dispositif est généralement décrit comme coupleur rapide de fil de point culminant.
- Si votre cylindre de gaz de propane vient avec une prise de la poussière, placez le bouchon anti-poussière sur la sortie de valve de cylindre toutes les fois que le cylindre n'est pas en service.

#### OPÉRATION DE COUPLEUR RAPIDE

**Pour relier le régulateur/hose à l'ajustage de précision de valve de cylindre de gaz de propane:** Serrez l'écrou de main sur le régulateur au-dessus de l'ajustage de précision de fil de point culminant sur la valve de cylindre. Tournez l'écrou de

main dans le sens des aiguilles d'une montre pour engager les fils et pour serrer jusqu'à ce que douillettement. L'utilisation des pinces ou de la clé ne devrait pas être nécessaire. Seulement le propane marqué par cylindres doit être employé.

**Pour débrancher:** Tournez l'écrou de main dans le sens contraire des aiguilles d'une montre jusqu'à isolé (fig. 8-1).

**Important:** Avant d'employer le gril, et ensuite chaque fois que le cylindre est enlevé et rattaché, examinez tous les raccordements pour déceler les fuites. Arrêtez les valves de gril et ouvrez la valve principale de cylindre, puis vérifiez les raccordements avec de l'eau savonneux. Réparez toutes les fuites avant d'allumer le gril.

**ATTENTION:** Tournez toujours la valve principale de cylindre de propane au loin après chaque utilisation, et avant de déplacer le gril et le cylindre, ou débrancher l'accouplement. Cette valve doit rester fermée et le cylindre a débranché alors que l'appareil n'est pas en service, quoique l'écoulement de gaz soit arrêté par un dispositif de sûreté quand le coupleur est débranché.

**Inspectez soigneusement** l'ensemble de tuyau chaque fois avant que le gaz soit allumé. Un tuyau criqué ou frangé devrait être remplacé immédiatement.

Si l'appareil est stocké à l'intérieur, le cylindre doit être débranché et enlevé. Des cylindres doivent être stockés hors des portes, hors de l'extension des enfants, et ne doivent pas être stockés dans un bâtiment, le garage, ou n'importe quel autre secteur inclus.

#### POUR VOTRE SÛRETÉ

- Ne stockez pas un cylindre de gaz disponible de propane dessous ou ne vous approchez pas de cet appareil.
- Ne remplissez jamais cylindre au delà de 80 pour cent de plein.
- SI L'INFORMATION DANS "A" ET "B" N'EST PAS SUIVIE EXACTEMENT, UN FEU CAUSANT LA MORT OU DES DOMMAGES SÉRIEUX PEUT SE PRODUIRE.

Fig. 8-1 type coupleur rapide de fil de point culminant d'I

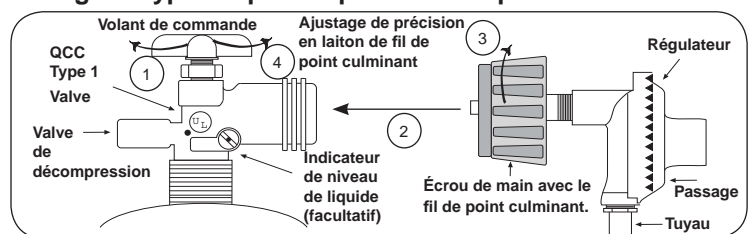

#### CLÔTURES DE CYLINDRE DE PROPANE

POUR VOTRE SÛRETÉ, vous devez fournir les ouvertures suivantes ci-dessous pour le drainage, l'air de recharge, et la ventilation en travers de n'importe quelle zone de stockage exposée à la fuite possible des raccordements de gaz, du gril, ou du cylindre de propane:

Un côté de la clôture de cylindre de gaz a laissé complètement ouvert de extérieur OU en fournissant quatre (4) ouvertures de ventilation. Deux ouvertures doivent être au niveau de valve de cylindre (approximativement 16" (40.6 centimètres) au-dessus du plancher) et sur les murs opposés de la clôture. Deux ouvertures supplémentaires doivent être au niveau de plancher des côtés opposés de la clôture. Les ouvertures de niveau de plancher doivent commencer au plancher et se prolongeront pas plus haut que 5" (12.7 centimètre) au-dessus du plancher. Chaque ouverture doit avoir un minimum de 10 pouces carrés (64.5 cm<sup>2</sup>) du secteur libre. Pour réaliser la ventilation appropriée, vous pouvez forer une série de trous, omettez le coulis des joints de maçonnerie, ou remplacez une brique avec un écran de tissu de matériel. Si le plancher dans le coffret est augmenté et l'espace sous le coffret est ouvert d'extérieur, les ouvertures inférieures de ventilation peuvent être dans le plancher.

# SAFE USE & MAINTENANCE OF PROPANE-GAS CYLINDERS

## IMPORTANT FOR YOUR SAFETY

### READ AND FOLLOW ALL WARNINGS PROVIDED WITH THE PROPANE-GAS CYLINDER.

When operating this appliance with a propane-gas cylinder, these instructions and warnings **MUST** be observed.

**FAILURE TO DO SO MAY RESULT IN A SERIOUS FIRE OR EXPLOSION.**

## CYLINDER/CONNECTOR REQUIREMENTS

- Propane-gas cylinders, valves, and hoses must be maintained in good condition and must be replaced if there is visible damage to either the cylinder or valve. If the hose is cut or shows excessive abrasion or wear, it must be replaced before using the gas appliance (see e.).
- This outdoor grill, when used with a cylinder, should be connected to a standard 5-gallon (20 lb.) propane-gas cylinder equipped with an OPD (Overfill Prevention Device). The OPD has been required on all cylinders sold since October 1, 1998, to prevent overfilling.
- Cylinder dimensions should be approximately 12" (30.5 cm) in diameter and 18" (45.7 cm) high. Cylinders must be constructed and marked in accordance with the *Specifications for Propane Gas Cylinders of the U.S. Department of Transportation (D.O.T.)* or the National Standard of Canada, *CAN/CSA-B339, Cylinders, Spheres, and Tubes for Transportation of Dangerous Goods*.
- The cylinder must include a collar to protect the cylinder valve, and the cylinder supply system must be arranged for vapor withdrawal.
- The pressure regulator and hose assembly used must match the specification for Type I by *ANSI Z 21.58-2007/CGA 1.6-2007* (see Fig. 9-1). This unit is not equipped with a propane regulator but if it is set up for use with propane gas, then the regulator must meet the above specific
- The propane-gas cylinder valve must be equipped with a cylinder connection coupling device, described as Type I in the standard defined in paragraph e. above. This device is commonly described as an Acme thread quick coupler.
- If the propane-gas cylinder comes with a dust plug, place the dust cap on the cylinder valve outlet whenever the cylinder is not in use.

## QUICK COUPLER OPERATION

**To connect the regulator/hose assembly to the propane-gas cylinder valve fitting:** Press the hand nut on the regulator over the Acme thread fitting on the cylinder valve. Turn the hand nut clockwise to engage the threads and tighten until snug.

The use of pliers or a wrench should not be necessary. Only cylinders marked "propane" may be used.

**To disconnect:** Turn the hand nut counterclockwise until detached (Fig. 9-1).

**Important:** Before using the grill, and after each time the cylinder is removed and reattached, check the hose for wear (see a.) and check all connections for leaks. Turn off the grill valves and open the main cylinder valve, then check connections with soapy water. Repair any leaks before lighting the grill.

**CAUTION:** Always turn the propane cylinder main valve off after each use, and before moving the grill and cylinder or disconnecting the coupling. This valve must remain closed and the cylinder disconnected while the appliance is not in use, even though the gas flow is stopped by a safety feature when the coupler is disconnected.

**Carefully** inspect the hose assembly each time before the gas is turned on. A cracked or frayed hose should be replaced immediately.

If the appliance is stored indoors, the cylinder must be disconnected and removed. **Cylinders must be stored out of doors, out of the reach of children**, and must not be stored in a building, garage, or any other enclosed area.

## FOR YOUR SAFETY

- DO NOT store a spare propane-gas cylinder under or near this appliance.
- NEVER fill the cylinder beyond 80-percent full.
- IF THE INFORMATION IN a. AND b. IS NOT FOLLOWED EXACTLY, A FIRE CAUSING DEATH OR SERIOUS INJURY MAY OCCUR.

Fig. 9-1 Type I Acme thread quick coupler

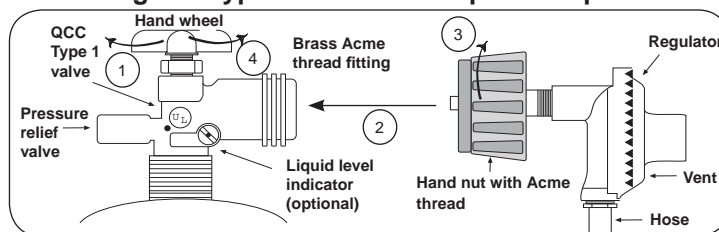

## PROPANE CYLINDER ENCLOSURES

FOR YOUR SAFETY, you must provide the openings listed below for drainage, replacement air, and cross-ventilation of any storage area exposed to possible leakage from gas connections, the grill, or propane cylinders:

One side of the gas cylinder enclosure left completely open to the outside **OR** by providing four (4) ventilation openings. Two (2) openings are to be at the cylinder valve level (approx. 16" [40.6 cm] above the floor) and on opposite walls of the enclosure. Two (2) more openings must be at the floor level on opposite sides of the enclosure. The floor-level openings must start at the floor and shall extend no higher than 5" (12.7 cm) above the floor. Each opening must have a minimum of 10 sq. in. (64.5 cm<sup>2</sup>) of free area. To achieve the proper ventilation, you may drill a series of holes, omit the grout from masonry joints, or replace a brick with a hardware cloth screen. If the floor in the cabinet is raised and the space beneath the cabinet is open to the outside, the lower ventilation openings may be in the floor.

Consult your gas supplier for ventilation and regulator requirements when connecting to a household propane supply.

# IDENTIFICATION OF GRILL CONTROLS

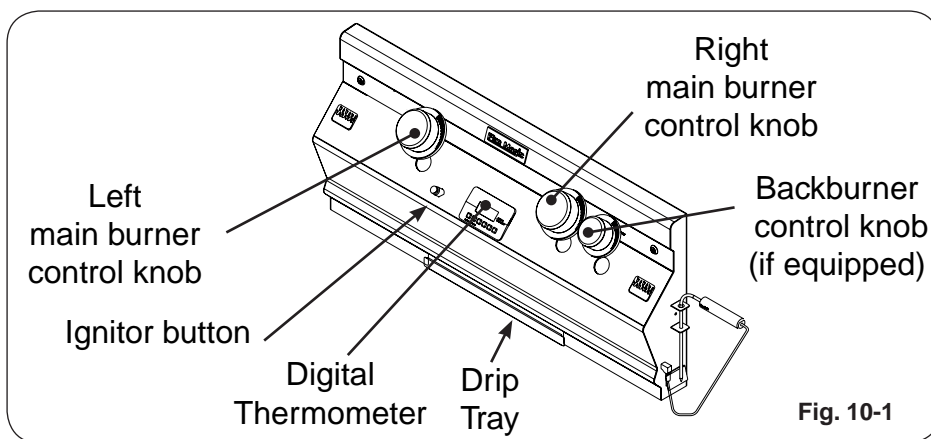

A430i and A530i controls

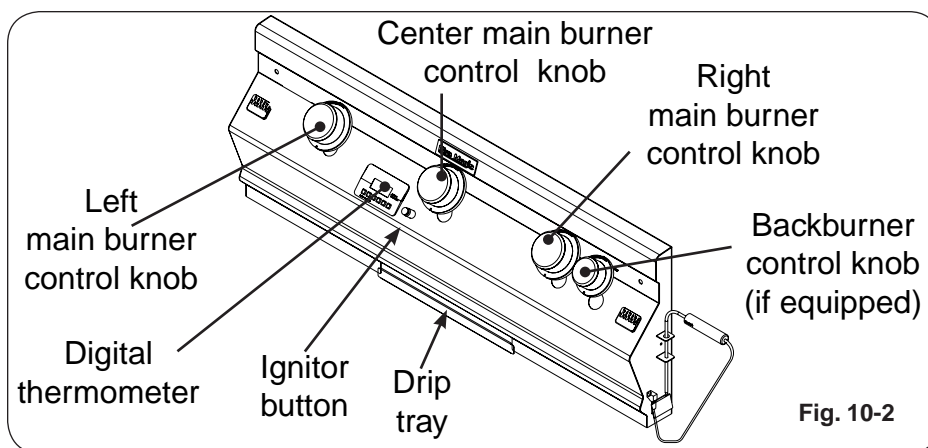

A540i, A660i, and A790i controls

# LIGHTING (IGNITION) INSTRUCTIONS

Read all instructions before lighting, and follow these instructions each time you light the grill.

## ELECTRONIC LIGHTING

**Note:** Electronic lighting requires an installed 9-volt battery with a good charge.

1. Open lids or remove covers from burners to be lit.
2. Turn all gas control knobs to their **OFF** positions.
3. Turn on the gas at its source.

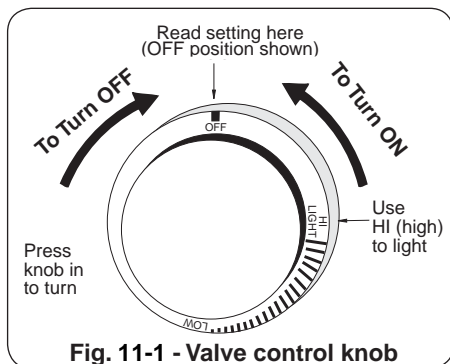

Fig. 11-1 - Valve control knob

4. Press and hold the stainless-steel ignitor button. The ignitors will produce a clicking sound. Immediately afterward, press in the control knob and turn it to the **HI LIGHT** position. Keep holding the ignitor button until the burner lights, then release the button.

**CAUTION:** If a burner does not light within five (5) seconds of turning on the control knob, depress the knob and turn it to the **OFF** position. WAIT FIVE (5) MINUTES before repeating step 4. If you smell gas, follow the instructions on the cover of this manual. If the burners still do not light after several attempts, refer to the instructions for manual lighting.

5. Repeat step 4 for each additional burner to be lit.

## REPLACING IGNITOR BATTERIES

To replace the nine-volt battery powering the ignitors, pull out the battery holder located on the outside left of the control panel. It may be necessary to lift the drawer up slightly before it will pull out. Disconnect the battery from the connector and replace it connecting the new battery and closing the drawer (see Fig. 11-3).

## WHEN USING A PORTABLE PROPANE TANK

Propane tanks are equipped with a safety shutdown device that may cause low or no gas pressure/flame at the burners if operating and lighting instructions are not followed exactly (See important note in the TROUBLESHOOTING section for more details.)

## MANUAL LIGHTING

**CAUTION:** Always wait five (5) minutes for gas to clear after any unsuccessful lighting attempt.

1. Follow steps 1 through 3 (left).
2. Insert either a burning long-barrel butane lighter or a burning long-stem match through the cooking grid opening to the top of the lighting tube. (Fig. 11-2). For backburners, hold the flame against the perforated material of the backburner.
3. While holding the match or lighter flame at the top of the lighting tube or next to the burner (backburner only), depress the appropriate valve knob and turn it counterclockwise to the **HI LIGHT** position. The burner will light.
4. If the burner does not light, **immediately depress the knob and turn the valve to OFF**. WAIT FIVE (5) MINUTES before repeating steps 2 through 4 of the MANUAL LIGHTING instructions.

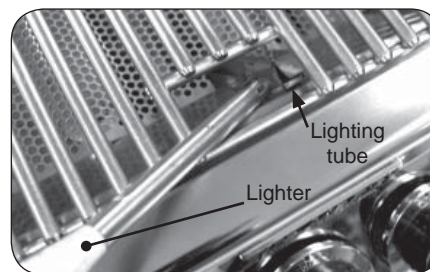

Fig. 11-2 - Manual lighting

## SHUTTING OFF THE GRILL

To shut off the grill, push in each valve control knob and turn it clockwise to the **OFF** position.

Always close the valve from the gas supply after each use of the grill.

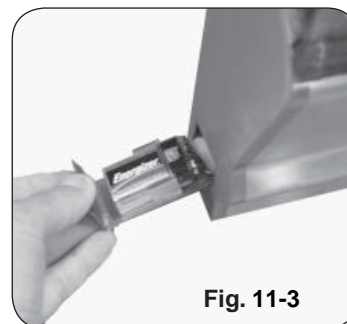

Fig. 11-3

## ALLUMER DES INSTRUCTIONS (D'ALLUMAGE)

Lisez l'instruction entière avant que s'allumant et suivez ces instructions chaque fois vous lumière le grill.

### ÉCLAIRAGE ÉLECTRONIQUE

1. Ouvrez tous les couvercles et enlevez toutes les couvertures.
2. Arrêtez tous les boutons de commande de gaz à leurs positions.
3. Allumez le gaz à sa source.

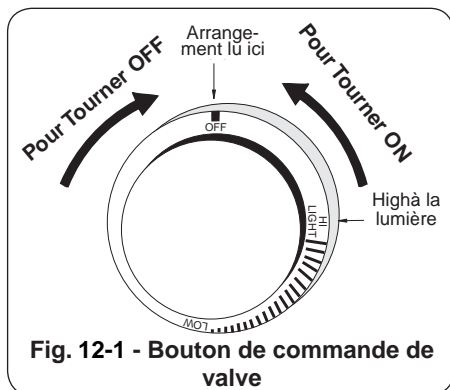

Fig. 12-1 - Bouton de commande de valve

**Note:** N'ouvrez pas plus d'une valve à la fois pour l'éclairage électronique ou manuel.

4. Appuyez sur et jugez le bouton d'ignitor le plus proche le bouton de commande pour que le brûleur soit s'est allumé. Continuez à se tenir dans le bouton d'ignitor pendant 5 secondes. Le bout de l'ignitor rougeoiera orange. Continuez à tenir le bouton d'ignitor tout en enfonçant le bouton de commande et en tournant le bouton dans la position **HI LIGHT**. Une fois que le brûleur s'allume, libérez le bouton d'ignitor.

**ATTENTION:** Si les brûleurs ne s'allument pas dans 5 secondes d'allumer le bouton de commande, enfoncez le bouton et tournez-l' à la position de repos. ATTENDEZ 5 MINUTES avant de répéter l'étape 4. Si vous sentez le gaz, suivez les instructions sur la couverture de ce manuel. Si les brûleurs ne s'allument toujours pas après que plusieurs tentatives, se rapportent aux instructions pour l'éclairage manuel.

5. Répétez l'étape 4 pour que chaque brûleur additionnel soit s'est allumé.

**Important:** En allumant le brûleur sous le tiroir de flavor/smoker, enlevez d'abord le tiroir de sorte que le brûleur puisse être facilement vu. Remplacez alors le tiroir après que le brûleur soit se soit allumé.

### POUR LE PROPANE SEULEMENT

Les réservoirs de propane sont équipés d'un dispositif d'arrêt de sûreté qui peut ne pas causer le bas ou aucun gaz pressure/flame aux brûleurs si le fonctionnement et allumer des instructions ne sont pas suivis exactement.

### ÉCLAIRAGE MANUEL

**ATTENTION:** Attendez toujours 5 minutes le gaz à l'espace libre après que n'importe quelle tentative non réussie d'éclairage.

1. Suivez les étapes 1 à 3 (à gauche).
2. Passez un allumeur brûlant de butane de long-baril ou une allumette brûlante de long-tige dans les grilles à cuire au dessus du tube d'éclairage. (Fig. 12-2). Pour des backburners, tenez la flamme contre le matériel perforé du backburner. Pour des sideburners, tenez la flamme contre le brûleur.
3. Tout en tenant l'allumette ou la flamme plus légère à côté du brûleur ou le dessus du tube d'éclairage, enfoncez le bouton approprié de valve et tournez-le dans le sens contraire des aiguilles d'une montre dans la position **HI LIGHT**. Le brûleur s'allumera.
4. Si le brûleur ne s'allume pas, enfoncez **immédiatement** le bouton et tournez le bouton de commande de brûleur à OFF. ATTENDEZ 5 MINUTES avant de répéter les étapes 2 à 4 des INSTRUCTIONS MANUELLES d'ÉCLAIRAGE.

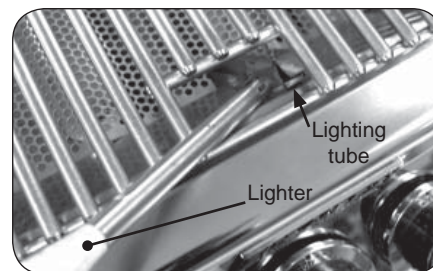

Fig. 12-2 - Éclairage manuel

### EN COUPANT LE GRIL

Pour couper le grill, enfoncez chaque bouton de commande de valve et tournez-le dans le sens des aiguilles d'une montre à la position de OFF. Fermez toujours la valve à l'offre de gaz après chaque utilisation du grill.

Pour remplacer la batterie de neuf-volt actionnant les ignitors, retirez le support de batterie situé sur l'extérieur à gauche du panneau de commande. Il peut être nécessaire de soulever le tiroir vers le haut légèrement avant qu'il retire. Démontez la batterie du connecteur et remplacez-la reliant la nouvelles batterie et fermeture le tiroir (voir la figue. 12-3).

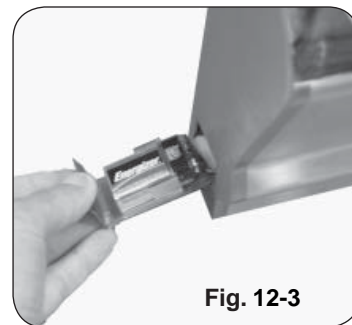

Fig. 12-3

# AURORA DIGITAL THERMOMETER

Your Aurora outdoor gas grill comes with a digital thermometer, which includes a built-in timer and alarms.

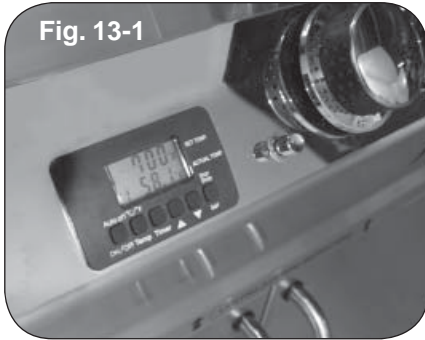

Fig. 13-1

The thermometer is located on the control panel between the knobs.

Plug in meat probe as shown in Fig. 13-6.

Thermometer battery access drawer (Fig 13-7).

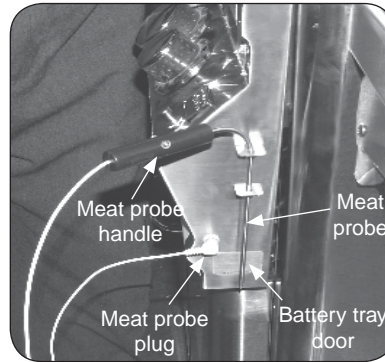

Fig. 13-5

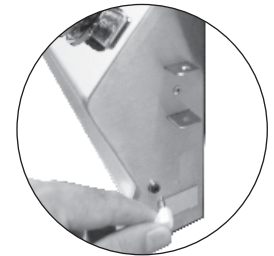

Fig. 13-6



Fig. 13-7

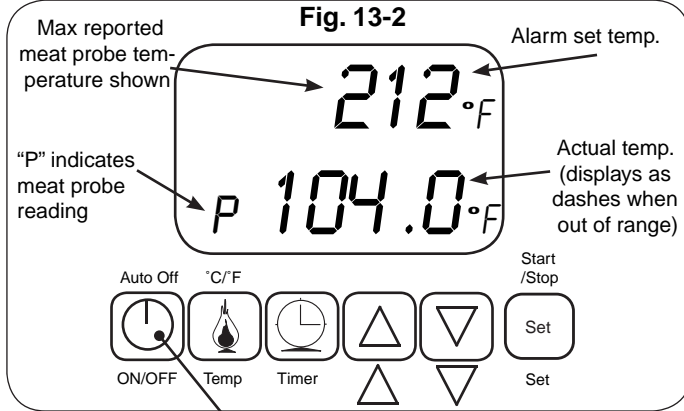

Fig. 13-2

Max reported meat probe temperature shown

Alarm set temp.

Actual temp. (displays as dashes when out of range)

"P" indicates meat probe reading

Start/Stop

Auto Off ON/OFF

Temp

Timer

Start/Stop Set

Press and hold to turn thermometer on or off.

Press any button to turn backlight on for 5 seconds

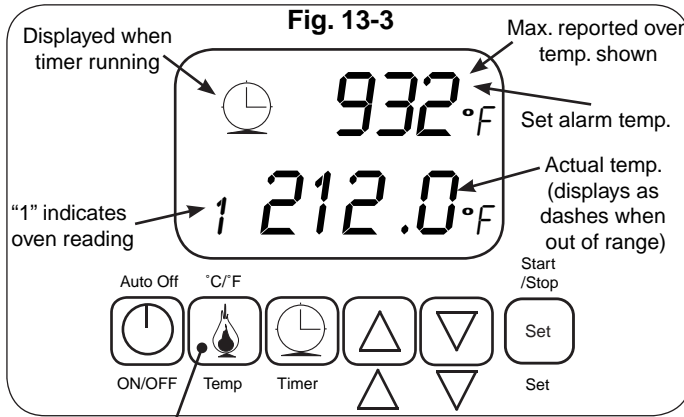

Fig. 13-3

Displayed when timer running

Max. reported oven temp. shown

Set alarm temp.

Actual temp. (displays as dashes when out of range)

"1" indicates oven reading

Start/Stop

Auto Off ON/OFF

Temp

Timer

Start/Stop Set

Press once to start/stop temp. alternation between probe and oven or return to temp. display mode from another mode.

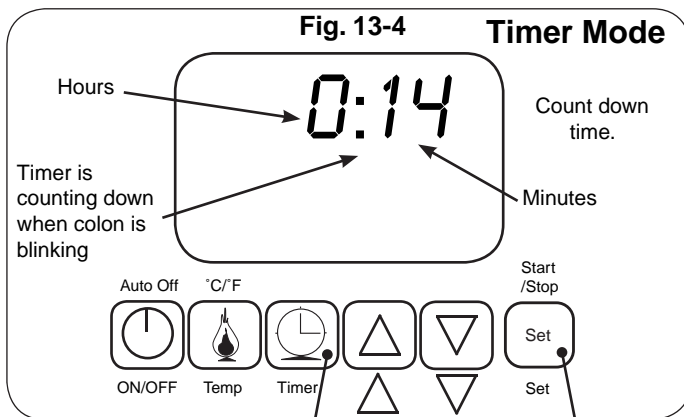

Fig. 13-4 Timer Mode

Hours

Count down time.

Minutes

Timer is counting down when colon is blinking

Start/Stop

Auto Off ON/OFF

Temp

Timer

Start/Stop Set

Press once to enter timer mode.

Press to enter/exit set time mode.

## Setting temperature alarm

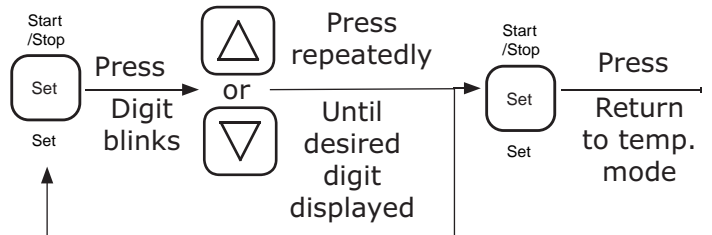

## Changing temperature units (Celcius/Farenheit)

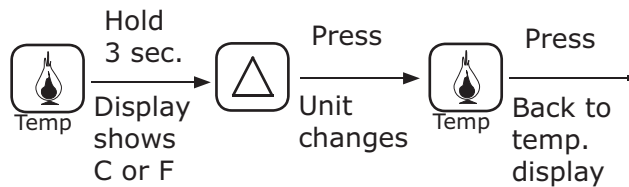

## Setting and starting the count-down timer

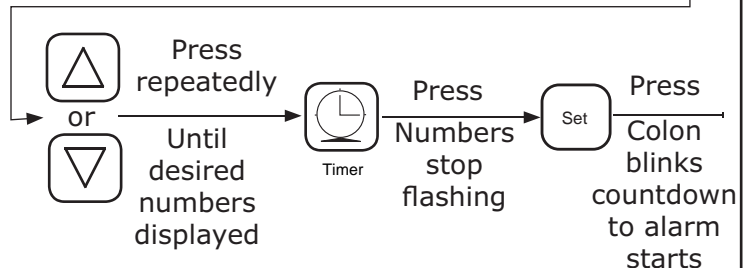
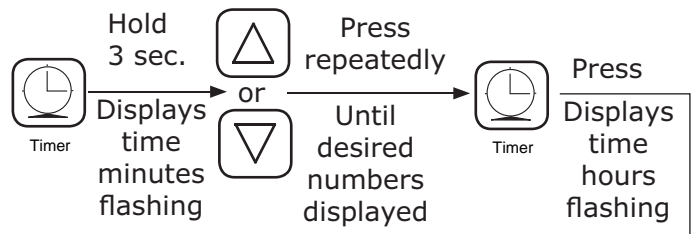

**Note:** Press any key to silence alarm when beeping. Alarm will not sound if timer is turned off.

Press Temp. to return from timer mode.

## OPTIONAL INFRARED BURNER OPERATION

The Fire Magic® infrared (IR) searing burner (optional) cooks with a powerful radiant heat.

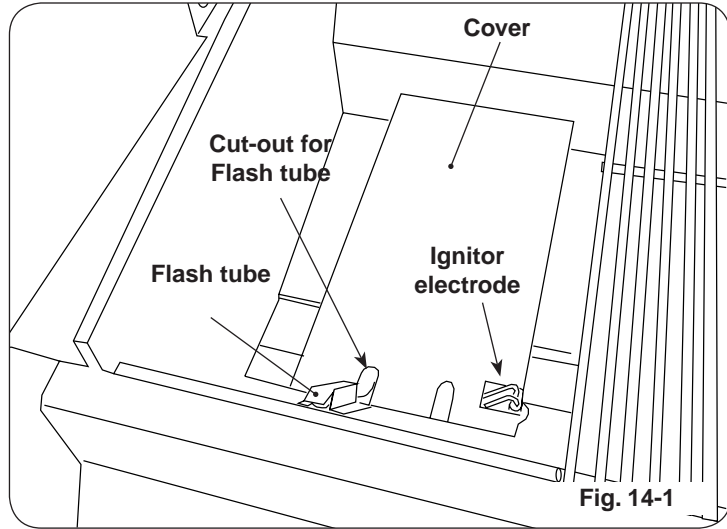

Fig. 14-1

Light the infrared burner following the LIGHTING INSTRUCTIONS in this manual or printed on the drip tray. Follow these guidelines when operating the Infrared burner:

- DO NOT place food on the cooking grid until the IR burner glows orange (Fig. 14-3). Drippings are heated and evaporate instead of sticking to and impairing burner function.
- When not in use, **always** cover the infrared burner with the stainless-steel cover. This protects the burner from drippings (from other cooking), airborne particles, and foreign objects (Fig. 14-2).
- Do not strike or scratch the burner ceramic as it may chip, crack, or break (Fig. 14-2).

**Note:** Digital thermometer does not give accurate readings for infrared burners.

**Important:** When grilling with the infrared burner, always place a cooking grid above it. The cooking grid must be removed for rotisserie cooking.

**CAUTION:** Never attempt to operate the IR burner with the protective cover in place.

### WARNING

Only handle the infrared burner cover when the grill is cold or with a well-insulated long-handled tool or heat resistant gloves.

#### SIDE VIEW (with cover on)

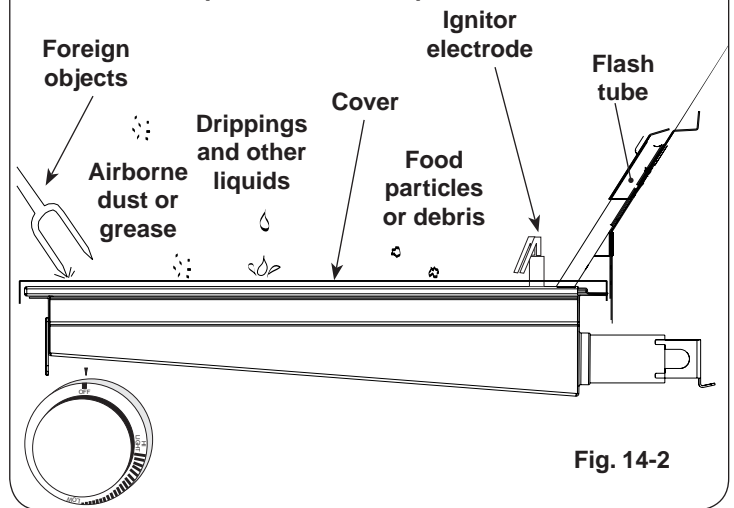

Fig. 14-2

Burner ceramic must be protected with cover when burner is not in use.

#### SIDE VIEW (burner on HI LIGHT and glowing orange)

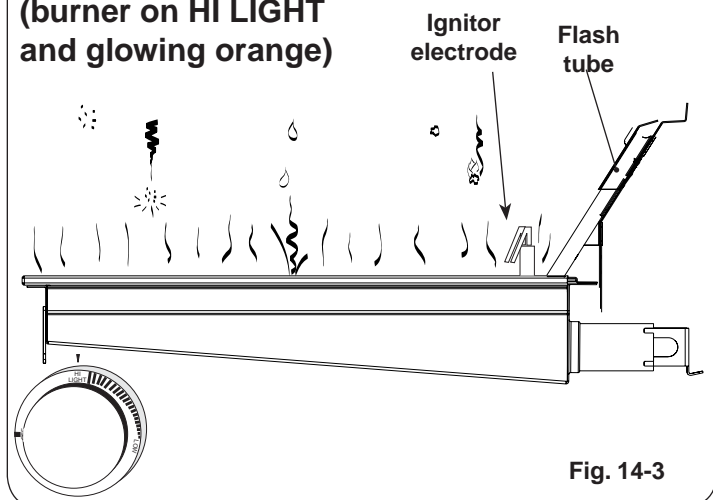

Fig. 14-3

Drips and particles evaporate before hitting infrared burner when cooking at the maximum setting.

# ROTISSERIE INSTRUCTIONS

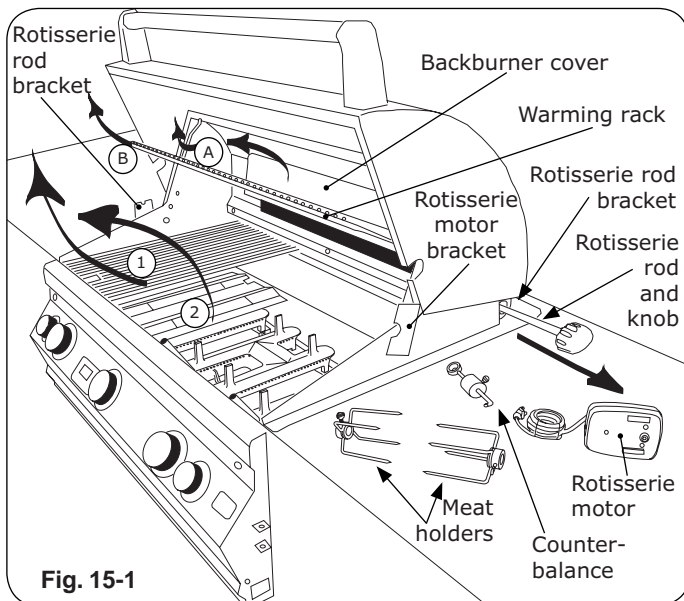

Fig. 15-1

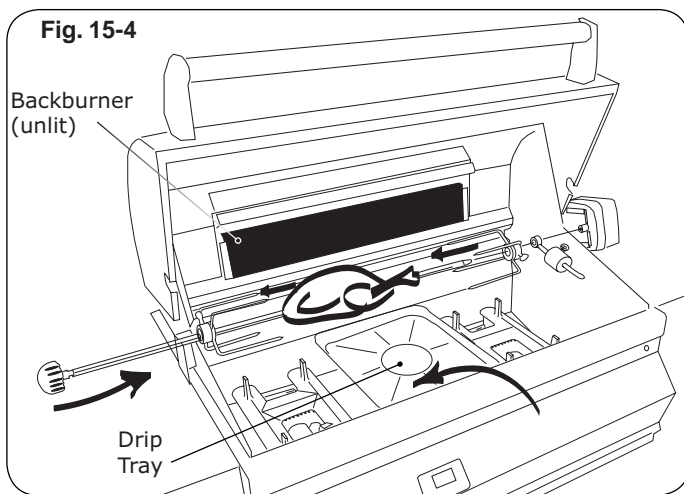

Fig. 15-4

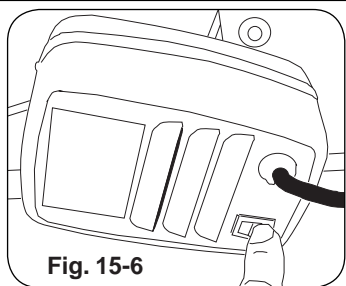

Fig. 15-6

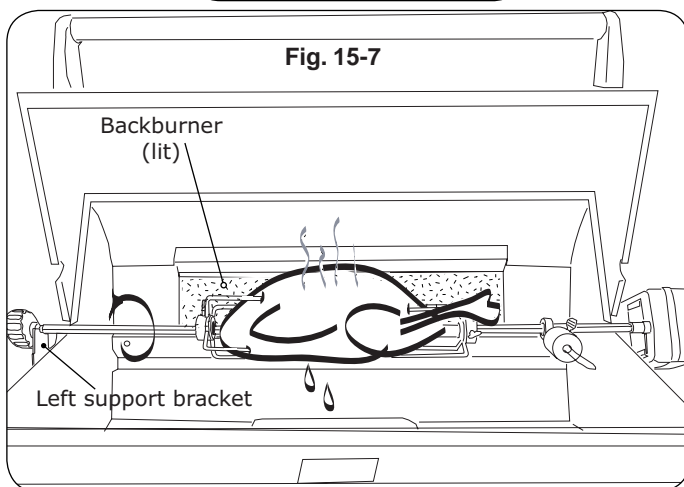

Fig. 15-7

**Important:** Turn the backburner to low or off when stopping the rotisserie, to prevent overcooking meat.

1. Remove warming rack, backburner cover, cooking grids, and flavor grids.
2. Slide rotisserie motor fully onto motor bracket on right (Fig. 15-2, 15-3) until the drive socket rests in the cut-out.
3. Remove rotisserie rod from rear bracket (Fig. 15-1) attach knob if necessary.

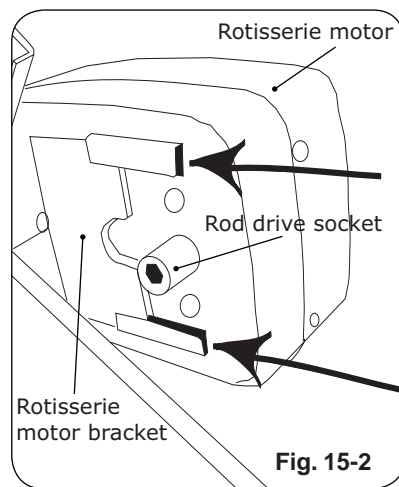

Fig. 15-2

4. Slide left meat holder into position on rod as shown in Fig. 15-4 and tighten screw.
5. Slide meat onto rod and into holder (Figs. 15-4, 15-7).

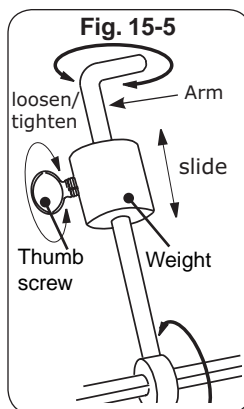

Fig. 15-5

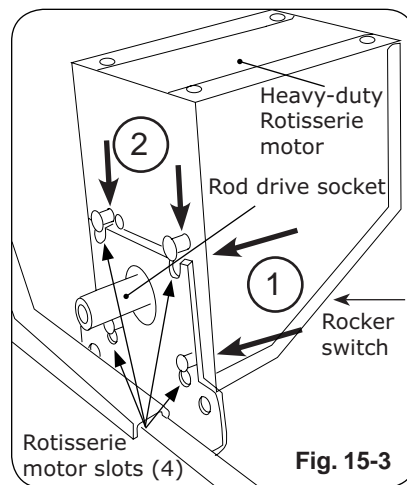

Fig. 15-3

6. Slide right meat holder onto rod and into meat (Fig. 15-4). Tighten thumb screw.
7. Support both ends of the rod so it spins freely on its axis. If meat weight is distributed unevenly, the rod will rotate until the heavy side of the meat points downward.
8. The counterbalance may then be attached to even weight distribution. Slide counterbalance onto rod next to the meat holder. Loosen the arm and point it upward opposite the heavy side of the meat. Tighten the arm.
9. Slide the counterbalance weight up or down until the rod rotates most evenly then tighten (Fig. 15-5).
10. Insert the pointed end of the rod into the motor drive socket and the groove next to the knob into the left support bracket.
11. To keep drippings off the burners and simplify cleanup, place Fire Magic® drip tray liners under the meat, if desired.
12. Plug-in the rotisserie motor and press the rocker switch to start (Fig. 15-6).
13. Light backburner per lighting instructions in this manual or on drip tray handle and close oven lid.

## ACCESSORIES

### THE GRILL BRUSH (OPTIONAL)

Purchase a Fire Magic® stainless-steel grill brush (sold separately) to keep your grill cleaner. It comes with scraper for large particles and a replaceable head with brass bristles for overall cleaning.



Fig. 16-1

Grill brush with replacement head

### THE WARMING RACK

The warming rack (Fig. 16-2) is packed separately.

To install the warming rack, lift the front of the rack up slightly and insert the rack hangers into the two holes in the back of the inner oven hood just above the backburner. Then lower the front of the rack into a level position to lock the rack in place.

To remove the warming rack, lift up on the front of the rack until the rack hangers pull free from their supporting holes.

**Note:** Removing the warming rack before using the rotisserie will leave more clearance for the meat being cooked.



Fig. 16-2 Warming rack in place inside oven

### THE COOKING GRID LIFTER

Hold the grid lifter by gripping the center section with the prongs pointing down (use an oven mitt or heavy glove if the grill is hot). Insert the notched end of the grid lifter into the cooking grid, in front of the midway point (front to back; Fig. 16-3), and central (left to right; Fig. 16-4). Twist the grill lifter (clockwise or counterclockwise) so the handle is parallel to the grill rods. This “seats” the spiked end of the grid lifter between two rods, enabling you to safely lift out the grid. Lift slowly and adjust the grid lifter, if necessary, for balance.

### THE DRIP PAN

The drip collection system allows you to brush or scrape excess dried residue from the grilling area directly into the drip pan (see PARTS LIST for drip pan location). To simplify cleanup when using the rotisserie, you may place a baking pan or foil under the rotisserie on top of the burners to collect the drippings. Clean the drip pan after each use.



Fig. 16-3



Fig. 16-4

Placement of the grid lifter in cooking grid

### THE FLAVOR GRID(S)

Place each flavor grid directly over a burner or burner pair. Center each grid over the burner, oriented as shown in Fig. 16-5.

**Note:** This allows heat from the burners to be evenly distributed throughout the cooking area. The flavor grids heat and cool quickly, making the grill very responsive to changes in heat from the burners.

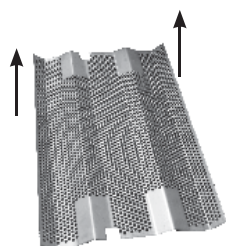

Fig. 16-5  
Edges angle upward



Fig. 16-6 Optional Rotis-A-Light

### THE ROTIS-A-LIGHT (OPTIONAL)

This flexible grill lighting solution (sold separately) will enhance your outdoor cooking experience by enabling you to continue cooking long after the sun has set. The Rotis-A-Light has two multi-directional flexi-angles, making this a completely versatile and indispensable light suitable for any grilling location.

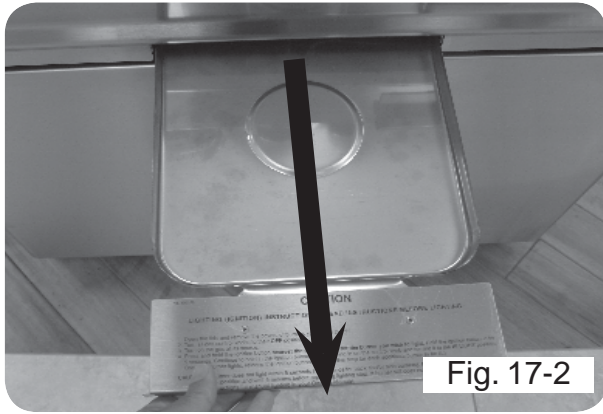

Fig. 17-2

Pull out the drip tray

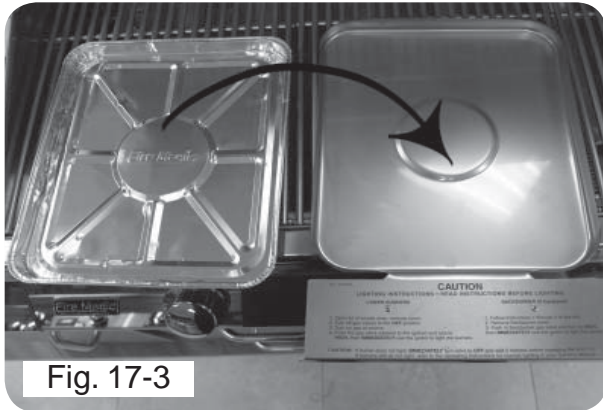

Fig. 17-3

remove a drip tray liner from the package

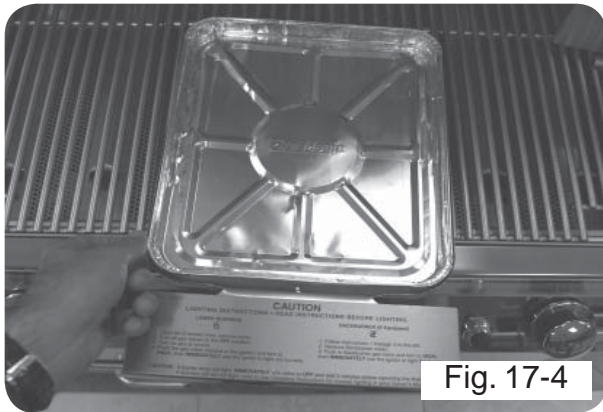

Fig. 17-4

Place the drip tray liner

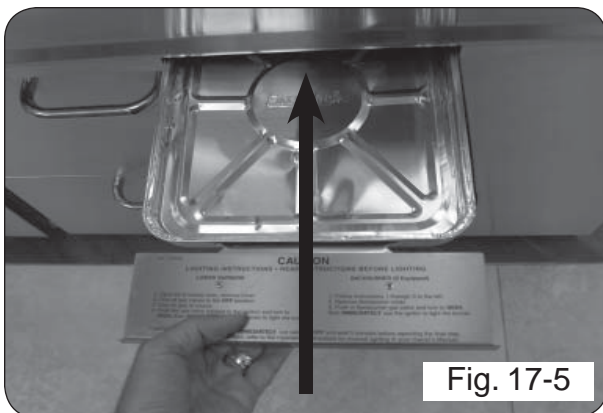

Fig. 17-5

Carefully slide the tray with liner back into the opening

Drippings from grilling flow through specially designed channels and collect in the drip tray. Check the drip tray regularly and empty when required.

Fig. 17-1



Your grill includes a pack of four (4) Fire Magic® drip tray liners (Fig. 17-1). For your convenience in cleanup, place a liner into the drip tray before grilling.

To fit a liner into the drip tray, pull out the tray (Fig. 17-2) and set it on a flat, level surface (Fig. 17-3). Place the liner in the drip tray as shown in Fig. 17-4 and carefully insert the tray back under the control panel (Fig. 17-5).

After each use, wait for the grill to cool and carefully pull out the drip tray to check it. When a liner is nearing full, carefully lift it out of the drip tray, lifting with both hands to keep the tray level until it is safely discarded. Then insert a new drip tray liner.

Order more drip tray liners through your local Fire Magic® dealer.

**Note:** The foil tray liner is also useful for setting on burners to cover them and catch drippings directly during rotisserie only cooking.

**Note:** There are easy to follow lighting instructions etched onto the top of the drip tray handle.

## CARE & CLEANING

### CARE AND CLEANING

Your new Fire Magic® grill represents the latest and most advanced technology available. In order to continue to enjoy the benefits of your grill and to protect your investment, we recommend the following:

Cover your grill with a Fire Magic® cover when not in use (see section below).

Clean it with a quality stainless-steel cleaner at least once a month (see Fig. 18-1).

**Note:** Due to the nature of stainless steel, surface iron oxide deposits may appear. Do not be alarmed – these deposits are removable with stainless-steel cleaner through periodic maintenance.

Check and clean the burner ports and carry-over slits for blockage at least annually by removing the burner (see orifice changing instructions) and visually inspecting the burner inlet for insects and nests. A clogged burner can lead to a fire beneath the grill.

The inside of the grill may be cleaned periodically with oven cleaner if desired. Follow the oven cleaner instructions for proper use.

By following these recommendations, you will enjoy the beauty and power of your grill for many years to come.



Fig. 18-1 - Wipe with grain

## OPTIONAL COVER

### PROTECTING YOUR GRILL

An optional heavy-duty cover will protect your grill's finish and preserve your investment. The water-repellent material will protect your grill from the weather.

Make sure to give the model number of your grill when ordering a cover.

**Important:** Allow your grill to cool before covering.

**Important:** Always close the gas-supply shutoff valve to the grill. If storing the grill for a long period of time, disconnect the grill from the gas supply completely.

Always check the burners before using the grill if it has been unused over a long period. Look for obstructions that may hamper performance and safe operation of your grill.



## TROUBLESHOOTING

If you have trouble with this Fire Magic® Aurora grill, please use this list to identify the problem. By trying one or more of the solutions to the possible cause, you should be able to solve the problem. If this list does not cover your present problem, or if you have other technical difficulties with the grill, please contact your local Fire Magic® dealer or visit our web site at [www.rhpeterson.com](http://www.rhpeterson.com).

PROBLEM	POSSIBLE CAUSE	CORRECTION
<b>Ignition system failure</b>	<ol style="list-style-type: none"> <li>1. Low battery.</li> <li>2. Improper air shutter adjustment</li> <li>3. Ignition wire disconnected</li> <li>4. Low gas pressure</li> <li>5. Front carry-over port</li> </ol>	<ol style="list-style-type: none"> <li>1. Replace ignitor battery.</li> <li>2. Adjust air shutters.</li> <li>3. Plug wires back into ignition switches.</li> <li>4. Have the gas co. check supply pressure.</li> <li>5. Clean burner ports</li> </ol>
<b>Insufficient heat</b>	<ol style="list-style-type: none"> <li>6. Improper air-shutter adjustment</li> <li>7. Using propane orifice for natural gas</li> <li>8. Low gas pressure/flame (propane)</li> <li>9. Low gas pressure/flame (natural)</li> </ol>	<ol style="list-style-type: none"> <li>6. Adjust air shutters.</li> <li>7. Check/change orifices.</li> <li>8. Shut off all valves, including propane tank, and follow lighting instructions exactly. (See important note* below.)</li> <li>9. Have the gas co. check pressure at grill.</li> </ol>
<b>Uneven heating</b>	<ol style="list-style-type: none"> <li>10. Burner ports partially blocked by debris</li> <li>11. Small spiders or insects in burner</li> <li>12. Improper air shutter adjustment</li> </ol>	<ol style="list-style-type: none"> <li>10. Remove burners and clean out ports.</li> <li>11. Inspect burners and orifices for spider webs or other debris that may block flow.</li> <li>12. Adjust air shutter.</li> </ol>
<b>Thermometer malfunction</b>	<ol style="list-style-type: none"> <li>13. Battery charge low</li> </ol>	<ol style="list-style-type: none"> <li>13. Replace batteries. Check connections to batteries.</li> </ol>
<b>Rotisserie noisy</b>	<ol style="list-style-type: none"> <li>14. Rotisserie out of balance</li> </ol>	<ol style="list-style-type: none"> <li>14. Adjust rotisserie counterbalance.</li> </ol>

**Table 2**

**\* Important:** Propane tanks are equipped with a safety shutdown device that may cause low or no gas/flame at the burners if operating and lighting instructions are not followed exactly. If you suspect the propane tank safety shutoff is in effect, shut off all burner control valves and the propane tank valve. Then read and follow the LIGHTING INSTRUCTIONS exactly. Lighting instructions are located in your owner's manual and printed on the grill's metal drip tray. If the problem persists, continue troubleshooting, or contact your local dealer or R. H. Peterson for assistance.

## CONVERTING THE GAS TYPE

### REGULATOR CONVERSION

The gas regulator, located behind the control panel, must be set for the type of gas used to fuel the grill. To check the regulator setting, remove the cap in the center of the regulator (Fig. 20-1). Holding the cap vertical (see Fig. 20-2), the letters at the bottom of the plastic stalk indicate the gas type for which the regulator is currently configured. If the bottom of the regulator stalk does not indicate the gas connected to the barbecue, remove the stalk from the cap, invert, and replace into center of cap. Replace cap on the regulator, screwing down until snug.

#### Gas Regulator

Note the cap on top.

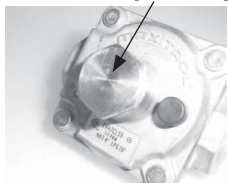
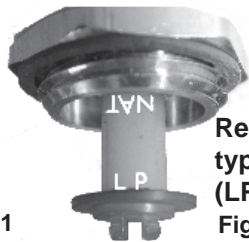

Fig. 20-1



Read gas type here. (LP shown)  
Fig. 20-2

### GAS ORIFICE CONVERSION

This Fire Magic® grill comes from the factory configured for one type of gas as marked on the label behind the control panel. When the grill is converted, this label must be replaced or updated to identify the new gas.

Each burner has a brass orifice, which can be replaced and must match the gas being used. When converting the grill to a different gas, each burner's orifice must be replaced with the corresponding orifice for the new gas.

Natural-gas to propane-gas conversions using a tank internal to a portable grill require installation of a propane tank holder (not included) for safety and compliance with the ANSI standards referenced on the cover of this document. This tank holder must be purchased separately from the manufacturer.

Consult Table 1 at the beginning of this document to determine the proper orifice sizes for each burner.

It is critical to the operation of each burner that its orifice be fully inserted into the center of its orifice opening.

#### **WARNING**

**Hazardous overheating will occur if a natural-gas orifice is used with propane gas.**

**CAUTION:** Make sure the grill is at a safe temperature and isolated from gas and electrical supplies before beginning.

For your safety, exercise caution, and make sure you have adequate hand protection, such as gloves, when handling metal parts.

Required tools:

- Phillips-head screwdriver (#2 medium)
- Needle-nose pliers
- $\frac{3}{8}$ " hex nut driver (deep socket)
- $\frac{5}{16}$ " hex nut driver

### CHANGING THE MAIN BURNER ORIFICES

1. Remove the cooking grid from above the burner you are working on by lifting it first from the front and set it aside.
2. Remove the flavor grid from above the burner you are working on and set it aside.
3. Remove the cotter pin from the left or right rear burner anchoring peg by pulling it straight out of the cotter pin hole using fingers or needle-nose pliers (Fig. 20-3).

**CAUTION:** The burner is heavy.

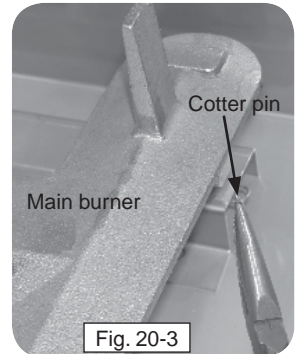

Fig. 20-3

4. Lift the back end of the burner out of the anchor peg holes, then move the burner toward the back of the grill to clear the gas inlet and set it aside.
5. Use a  $\frac{3}{8}$ " hex nut driver to remove the exposed orifice (Fig. 20-4) and replace it with the correct orifice for the new gas. (See Table 1 at the beginning of this document for orifice sizes.)
6. Replace the burner by first sliding the open cylindrical end of the burner around the orifice, enveloping it and centering on it, then lower the back end anchor pegs into the anchor peg holes.

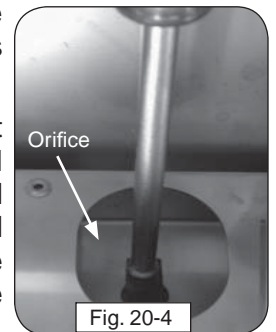

Fig. 20-4

**Note:** It is critical to the continued safe functioning of the burner that the orifice is centered and completely inside the burner gas conduit.

7. Reinsert the cotter pin into the right rear burner anchor peg using fingers or needle-nose pliers.
8. Replace the flavor grid and then the cooking grid so that the cutout section of the cooking grid is lined up with the lighting tube.

Repeat these steps for each main burner.

### CHANGING THE BACKBURNER ORIFICE (IF EQUIPPED)

1. Remove the warming rack if installed and set it aside.
2. Remove the backburner cover.
3. Unscrew all backburner access plate screws using a Phillips-head screwdriver and set them aside.

## CONVERTING THE GAS TYPE

4. Remove the backburner plate by pulling the bottom toward the front of the grill and rotating it upward and outward until the two top tabs attached to back wall of the oven can be removed from the slots in the top of the plate.
5. Remove the backburner assembly retaining screw on the lower left of the backburner using a Phillips-head screwdriver and set it aside.
6. Pull the wire from the ignitor electrode (Fig. 21-2), then remove the backburner retaining screw on the left of the backburner (Fig. 21-1) using a Phillips screwdriver.

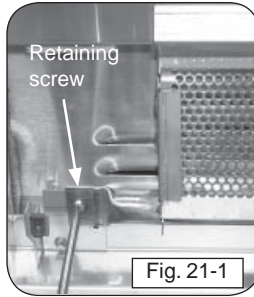

**CAUTION:** Be careful not to damage the wires connected to the backburner assembly.

7. Use a  $\frac{3}{8}$ " hex nut driver to remove the exposed orifice and replace it with the correct orifice for the gas being converted to (See Table 1 for size).
8. Replace the backburner assembly and reinsert the retaining screw. Center the backburner assembly so that the backburner plate will fit over it. Tighten the retaining screw using a Phillips-head screwdriver.
9. Replace the backburner plate by first inserting the tabs above into the slots in the top of the plate and then rotating the bottom downward and inward.
10. Replace all the backburner plate screws using a Phillips-head screwdriver.

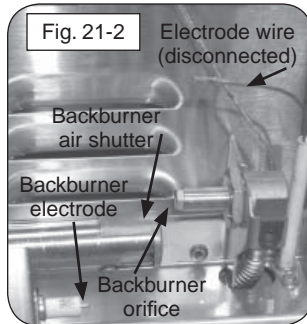

## CHANGING AN INFRARED BURNER ORIFICE (IF EQUIPPED) →

1. Remove the cooking grid from above the burner on which you are working by lifting it first from the front and set it aside.
2. Unscrew both lighting tube hex head screws with a  $\frac{3}{8}$ " hex nut driver.
3. Remove the infrared burner by lifting the back of the burner up so that both tabs are freed from their slots, then lift the burner toward the back of the fire box and upward. Set the burner aside.
4. Use a  $\frac{3}{8}$ " hex nut driver to remove the exposed orifice and replace it with the proper orifice for the new gas (see Table 1 for sizing).
5. Replace the infrared burner by first sliding it over the orifice, then lowering the two tabs under the back of the burner into the slots in the back burner rest.
6. Reattach the lighting tube and replace the grill so that the cut-out section is in front.

## BURNER AIR SHUTTER ADJUSTMENT

### AIR SHUTTER ADJUSTMENT

**Important:** Air shutters are preset at the factory based on the gas the grill is built to burn. However, altitude or other local conditions may require air shutter adjustment for proper combustion.

### MAIN BURNER

Flames from a properly adjusted main burner with no wind or breeze present will appear fairly steady, consistent, and almost entirely blue. The extreme tips of the flames may be light yellow. If the tip of a flame were to turn orange, it should only do so briefly and then become blue or light yellow again. The flames will appear to burn while touching the burner ports (see Figure 22-1).

If the flames have orange in them and appear to undulate slowly from side to side, or if some of them appear to lift off the burner instead of touching it, then adjust the air shutter, as instructed below.

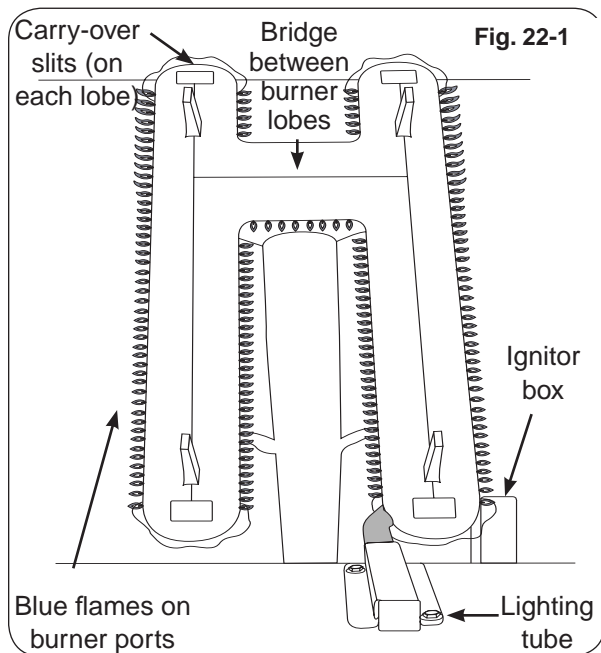

Fig. 22-1

**CAUTION:** Turn all burner control knobs to the **OFF** position and turn off the gas supply at the source before removing or adjusting a burner.

### **WARNING**

Wait for the burner to be cool or use heavily insulated heat-resistant gloves when handling the burner.

1. Follow the safety precautions and steps for main burner removal in the **CHANGING THE MAIN BURNER ORIFICES** section (steps 1-4).

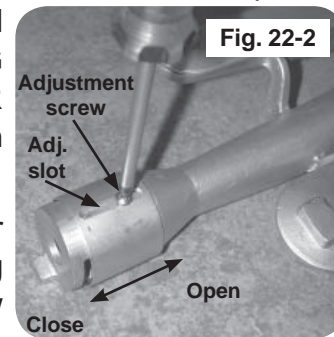

Fig. 22-2

2. Adjust the air shutter opening by loosening the adjustment screw with a screwdriver, then sliding the air shutter backward or forward to open or close the air shutter opening (see Fig. 22-2).

Shutter Setting	Flame Condition
Open too far	Flames shorten and lift off the burner
Ideal setting	Blue flames just touching burner (may have light-yellow tips)
Closed too far	“Lazy” flames with orange in them

Too large an air shutter opening will allow too much air into the burner, which will cause the flames first to shorten and then to appear to lift up off the ports. For the bottom of the flames to move closer to the ports, close the air shutter more.

If the air shutter opening is too small or closed, the flames will present consistently orange tips and become “lazy,” slowly undulating back and forth.

For propane gas, ideal settings tend to be just slightly open. For natural gas, which generally requires less primary air than propane, the main burner air shutter may be nearly closed.

3. Adjust the air shutter opening and then replace the burner (steps 6-8 in the **CHANGING THE MAIN BURNER ORIFICES** section)
4. Follow the lighting instructions in this manual to light the burner.
5. Repeat steps 1-4 until the flames appear to touch the burner ports, burning fairly steadily and almost entirely blue with occasional light-yellow tips (see Fig. 22-1).

## BURNER AIR SHUTTER ADJUSTMENT (Continued)

### BACKBURNER

The backburner is set at the factory and will not require adjustment unless this unit is converted or used at an elevation above 2,000 ft.

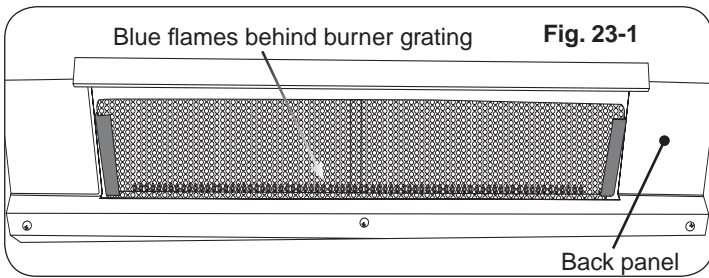

Flames from a properly adjusted backburner will appear as a horizontal line of even blue flames along the bottom of and behind the backburner grating. The grating itself will glow red after it heats up.

**Note:** It is normal for the backburner to smoke when it is first used. Burning the backburner on **HI LIGHT** for approximately 15 minutes will eliminate the smoking.

If, instead of being blue and even, the backburner flames appear to have orange in them and waver slowly left and right, or if the flames appear to lift off the burner, adjust the backburner air shutter by following the steps below.

The backburner air shutter adjustment is located behind the right side of the access panel in the back of the oven, above the cooking grid.

**Note:** It is only necessary to remove the backburner back panel, not the backburner, when adjusting the backburner air shutter.

1. Follow the safety precautions and steps for backburner back panel removal (steps 1-4) in the CHANGING THE BACKBURNER ORIFICE section.

**CAUTION:** The backburner air shutter can be safely adjusted with the backburner lit if it is adjusted using a long-handled screwdriver or well-insulated fire and heat-resistant gloves.

2. Adjust the air-shutter opening by loosening the adjustment screw with a screwdriver, then sliding the air shutter backward or forward to open or close the air shutter opening (see Fig 23-2). Watch the backburner flames while adjusting the air shutter.

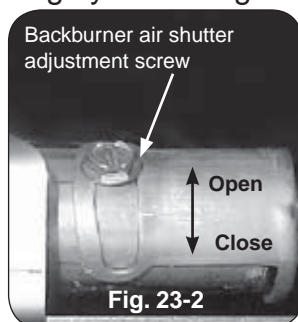

Too large an air shutter opening will allow too much air into the burner, which will cause the flames first to shorten and then to appear to lift up off the ports. For the bottom of the flames to move closer to the ports, close the air shutter more.

If the air shutter opening is too small or closed, the flames will present consistently orange tips and become "lazy," slowly wavering left and right.

3. Continue adjustment until the flames appear to touch the burner ports, burning fairly steadily, consistently, and almost entirely blue with some light-yellow tips (see Fig. 23-1), then retighten the backburner air shutter adjustment screw.
4. Replace the burner access plate (step 8 in the CHANGING THE BACKBURNER ORIFICE section).

# WARRANTY

**PLEASE COMPLETE AND RETURN YOUR REGISTRATION CARD, WHICH IS INCLUDED WITH YOUR FIRE MAGIC® GRILL**

**LIFETIME WARRANTY** - Fire Magic® cast stainless-steel burners, stainless-steel rod cooking grids, and stainless-steel housings are warranted for as long as you own your Fire Magic® grill.

**FIFTEEN-YEAR WARRANTY** - Fire Magic® cast brass burners, brass valves, backburner assemblies (except ignition parts), and manifold assemblies are warranted for 15 years from the date of purchase of your Fire Magic® grill.

**THREE-YEAR WARRANTY** - Fire Magic® sideburners and all other Fire Magic® grill components (except ignition and electronic parts) are warranted for three (3) years from the date of purchase of your Fire Magic® grill.

Fire Magic® ignition systems (excluding batteries), electronic components (including lights and thermometers), and grill accessories are warranted for one (1) year from date of purchase.

**PLEASE KEEP A COPY OF YOUR SALES SLIP FOR PROOF OF PURCHASE**

This warranty applies to the original purchaser and to single family residential use only. It commences from date of purchase, and is valid only with proof of purchase.

This warranty does not cover parts becoming defective through misuse, accidental damage, electrical damage, improper handling, storage, and/or installation. Product must be installed (and gas must be connected) as specified in the instructions or operator's manual, by a **qualified professional installer**. Accessories, parts, valves, remotes, etc., when used must be Peterson Co. product.

This warranty **does not** apply to rust, corrosion, oxidation, or discoloration, unless the affected component becomes inoperable. It **does not** cover labor or labor-related charges.

This warranty specifically excludes liability for **indirect, incidental**, or consequential damages. Some states do not allow the exclusion or limitation of incidental or consequential damages, so the above exclusion may not apply to you. This warranty gives you specified legal rights, and you may have other rights that may vary from state to state.

For additional information regarding this warranty, or to place a warranty claim, contact the R.H. Peterson dealer where the product was purchased.

## ROBERT H. PETERSON CO.

Quality Check

Date: \_\_\_\_\_

Orifice # (Main): \_\_\_\_\_

Orifice # (Other): \_\_\_\_\_

Leak Test: \_\_\_\_\_

Burn Test: \_\_\_\_\_

Gas Type: NAT. / PROPANE

Model #: \_\_\_\_\_

Serial #: \_\_\_\_\_

Air Shutter: \_\_\_\_\_

Inspector: \_\_\_\_\_